

Mental Illness and the Law: A Guide for Legal Professionals



Virginia Department of Behavioral Health & Developmental Services

Module 1:

Improving Outcomes for Persons with Mental
Illness in the Criminal Justice System:

The Sequential Intercept Model



National Jail Perspective

Scope of the Problem



- GAINS Center estimates approximately 1,100,000 persons with serious mental illness are admitted annually to U.S. jails.
 - Among these admissions, 72% also meet criteria for co-occurring SU disorder.
- 14.5% of male and 31.0% of female inmates recently admitted to jail have a serious mental illness.
- The vast majority will be released into the community.

Virginia Jail Perspective

Inmates with Mental Illness



2012 Compensation Board Jail/Mental Health Survey of 64 Local and Regional Jails

- **23.71%** of the local and regional jail inmate population known or suspected to be mentally ill.
- **48.13%** of the mentally ill population had been diagnosed as having a *serious mental illness*.

ADP for July 2012:

6,982	State Responsible
19,241	Local Responsible
446	Ordinance Violators
<hr/>	
26,669	Total (31.83% Pretrial)

Virginia DOC Perspective

- The Department of Corrections is one of the largest providers of mental health services in Virginia.
- 2,155 state responsible* offenders released into the community** in FY 2012 (19% of state responsible releases) had a Mental Health Impairment.
- DOC defines mental health impairments ranging from minimal impairment (e.g., history of illness) to severe impairment (e.g., symptomatic psychosis).

* State Responsible offenders are felons with a sentence of at least one year.

** Excludes 89 releases due to death; 35 of whom had a Mental Health Impairment.

Sequential Intercept Model

The Basis for Cross-Systems Mapping

Cross-Systems Mapping is an activity which depicts contact/flow within the criminal justice system.

A tool to:

- ✓ Help transform fragmented systems,
- ✓ Identify local resources, gaps and
- ✓ Help identify where to begin interventions.



Sequential Intercept Model

Patty Griffin, PhD & Mark Munetz, MD



People move through criminal justice system in predictable ways.

Illustrates key points to “intercept” individuals to ensure:

- ✓ Prompt access to treatment.
- ✓ Opportunities for diversion.
- ✓ Timely movement through criminal justice system.
- ✓ Linkage to community resources.



Five Key Points of Interception

1. Law enforcement / Emergency services.
2. Booking / Initial court hearings.
3. Jails / Courts.
4. Re-entry from jails/prisons.
5. Community corrections / Community support.

Sequential Intercept Model: Virginia

ACTION: Sequential Intercepts for Change: Virginia Criminal Justice - Mental Health Partnerships

10/2008

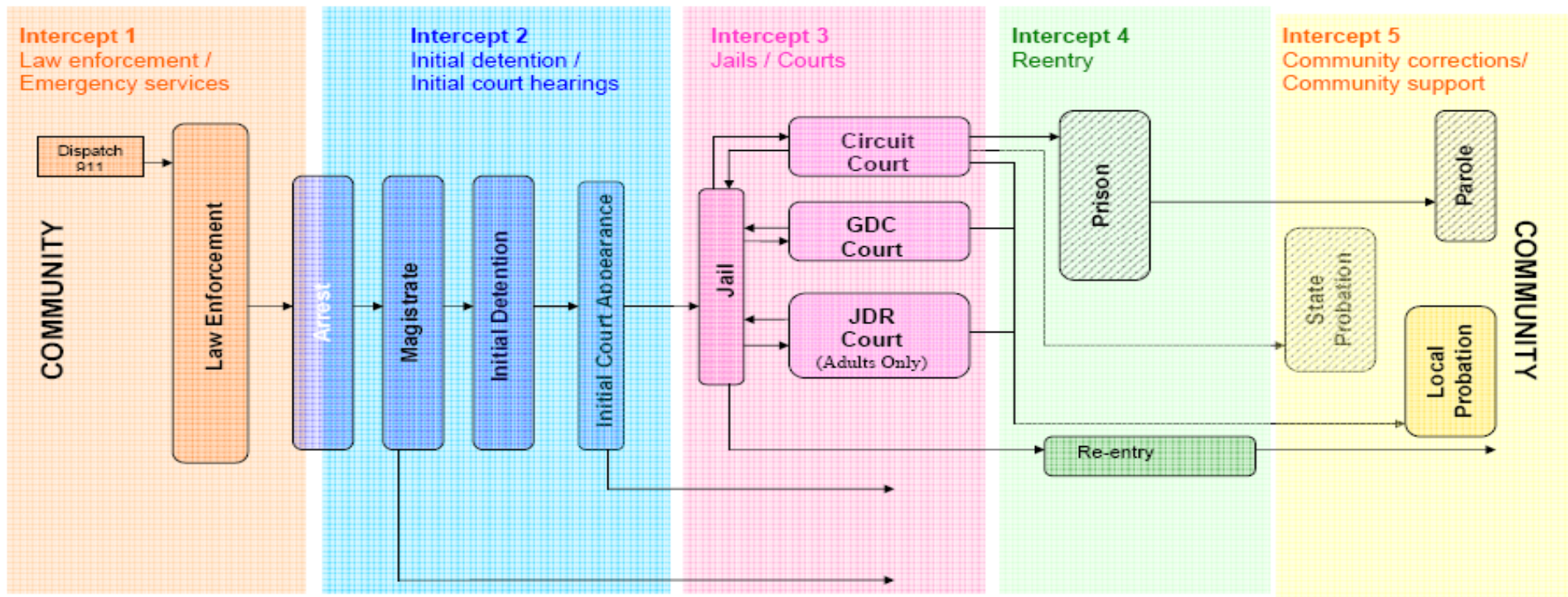

Pre-booking Jail Diversion



Intercept 1

Law enforcement / Emergency services

Dispatch
911

COMMUNITY

Local Law Enforcement

Arrest

Model Programs: *Intercept 1*

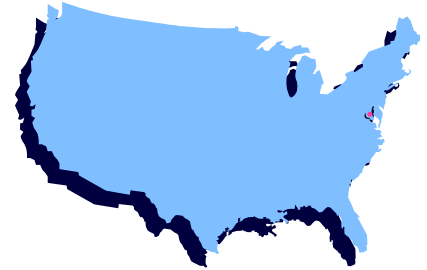

- National examples:
 - Crisis Intervention Teams (CIT):
 - Memphis, TN Law Enforcement approach
 - Mental Health First Aid:
 - Two day proprietary community introduction to mental health response
 - System-wide Mental Assessment Response Team (SMART):
 - Police/mental health secondary co-response (Los Angeles)

Model Programs: *Intercept 1*

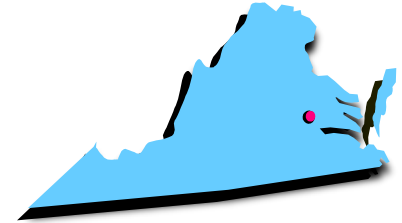

- Virginia examples:
 - 30 CIT initiatives utilizing the Memphis Model of CIT:
 - Statutory oversight by DBHDS and DCJS (Section 9.1- 187, et. seq.)
 - Collaboration, Infrastructure, Training make up a CIT Program
 - Essential Elements of CIT Developed by the Virginia CIT Coalition

(see vacitcoalition.org for additional information)

Post-Booking Diversion Options

After arrest has been made.

Intercept 2 Initial detention/Initial court hearings

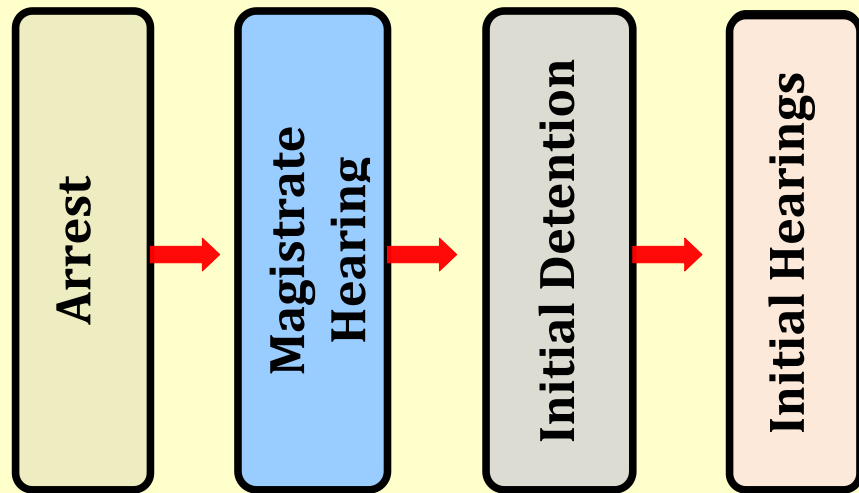

Model Programs: *Intercept 2*

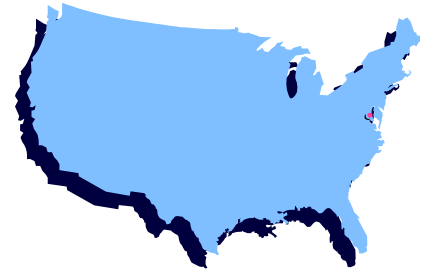

- National Examples:
 - The Jericho Project:
 - Shelby County/Memphis, TN Public Defender-operated pre-trial diversion.
 - Connecticut First Appearance diversion program:
 - Statewide initiative in 4 high population cities
 - Honolulu Diversion Project:
 - 24/7 coverage at the jail for post-booking diversion
 - Bucks and Montgomery Counties (PA) Emergency Services:
 - Post-booking directly into MH treatment center or community care

Model Programs: *Intercept 2*

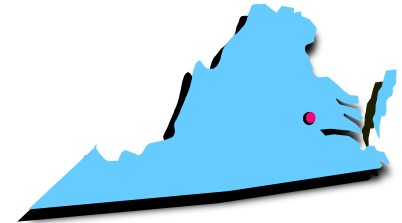

- Virginia examples:
 - New River Valley Bridge Program:
 - Post –booking, pre-trial release to wrap around forensic informed services program
 - Arlington Magistrates Post-Booking Release Program:
 - Identification and linkage to services from jail/accelerated access to psychiatric care

**Specialty
Courts?**

**Other Court
Programs**

**Jail-Based
Diversion
Programs**

&

**Jail Mental
Health Services**

**State Hospital
Treatment**

Intercept 3

Jails/Courts

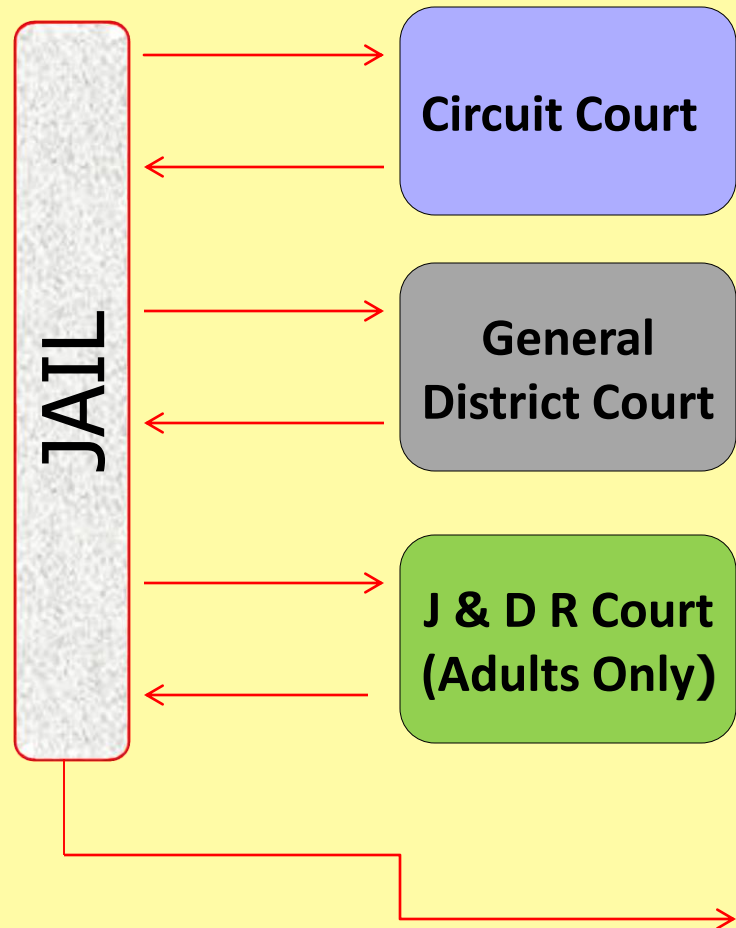

Model Programs: *Intercept 3*

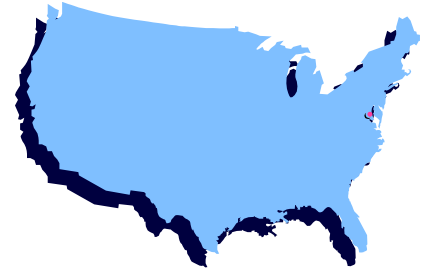

- National Examples:
 - Brooklyn, NY Mental Health Court:
 - Pretrial diversion of defendants with mental illness with felony or misdemeanor charges
 - Maryland's TAMAR and TAMAR's Children Programs:
 - Trauma recovery program for women inmates in Maryland jails

Model Programs: *Intercept 3*

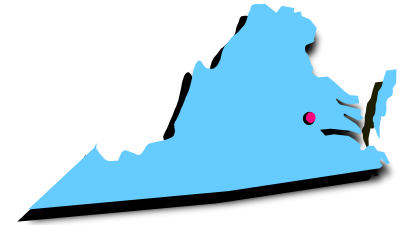

- Virginia examples:
 - Norfolk MH Court and Norfolk MH Docket:
 - CSB and CC staff develop post-plea community MH treatment and supervision plan
 - Petersburg MH Docket:
 - Therapeutic justice programs for MH consumers currently involved in the justice system which offer sentencing options designed to reduce recidivism

Model Programs: *Intercept 3*

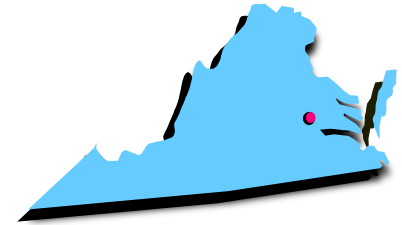

- Virginia examples (cont.)
 - Richmond MH Docket:
 - A multipurpose GDC docket with the primary goal of early identification of misdemeanor offenders with mental illness and diversion to community services. Offenders are assessed for MHASP eligibility and monitored by specially trained probation officers
 - HPR IV Jail Team:
 - Provides in-jail competency restoration, post-booking diversion and in-jail services for inmates with mental illness in the greater Richmond area

Intercept 4 Reentry (Planning)

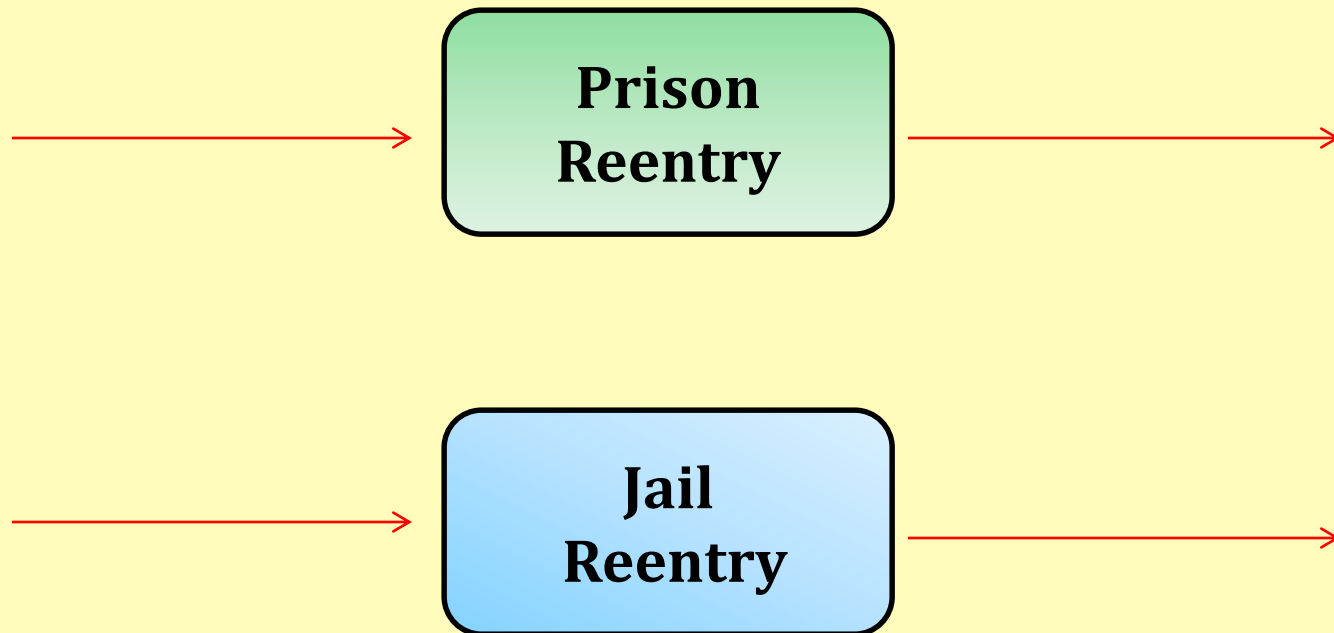

Model Programs: *Intercept 4*

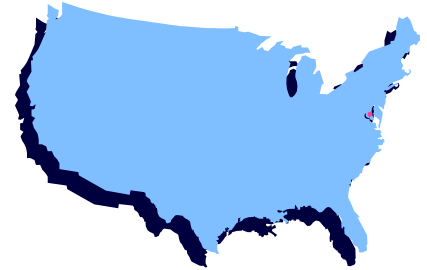

- National Examples:
 - NY State Probation Division:
 - Has integrated reentry program for inmates with mental illness from state prisons to New York City
 - Michigan DOC:
 - Comprehensive reentry program with MH component

Model Programs: *Intercept 4*

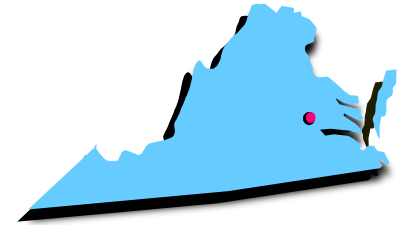

- Virginia examples:
 - Northern Virginia CSBs (HPR II):
 - 5 localities have Forensic Discharge Planners; promote continuity of care from jail and state hospitals to community
 - Alexandria CORE Program:
 - Funds a full time mental health trained PO with MH/SA caseload
 - Referrals directly from Circuit Court or DOC inmates upon release
 - Strong collaboration and coordination of services between PO and CSB

Intercept 5

Community corrections/Community support

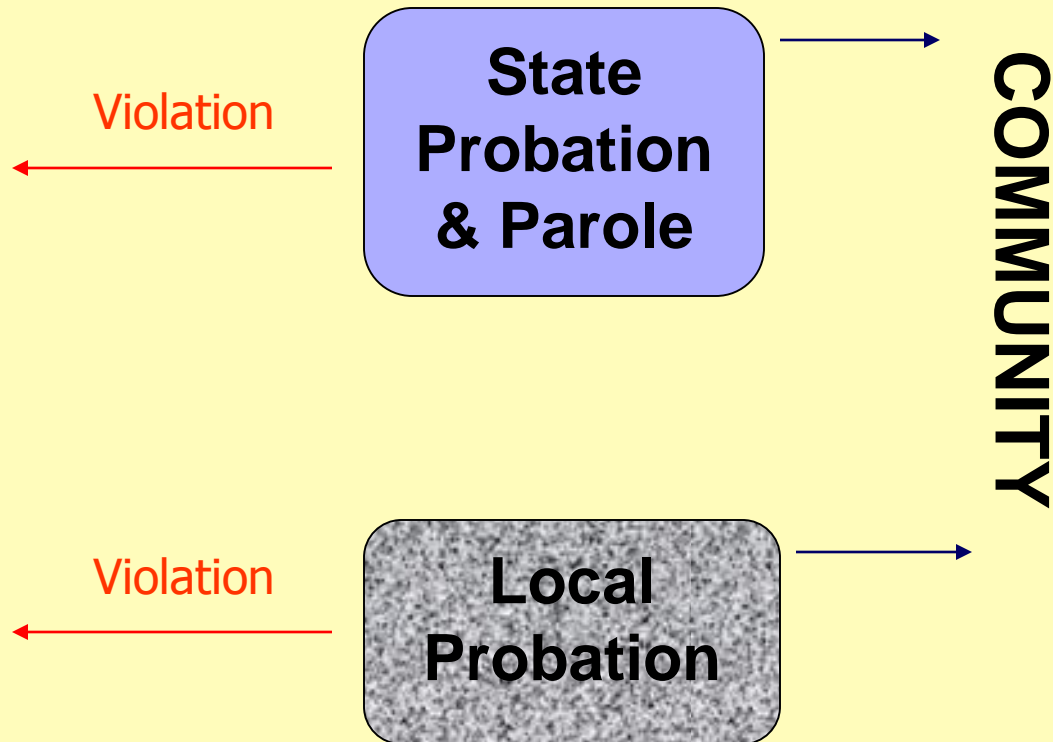

Model Programs: *Intercept 5*

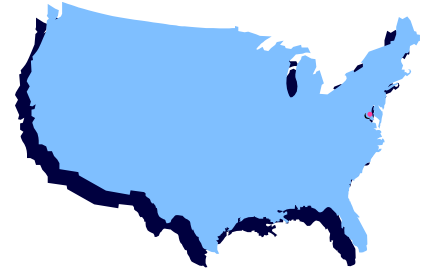

- National Examples:

- Lane County, OR:

- Innovative approach to preserving access to Medicaid and SSI/SSDI benefits for reentering inmates with disabilities

- Miami, FL Housing and Transition Program:

- Provides housing placement assistance and follow up monitoring for diverted inmates with mental illness

- San Francisco, CA:

- FACT Team: Forensic Assertive Community Treatment for Post-booking directly into MH treatment center or community care

Model Programs: *Intercept 5*

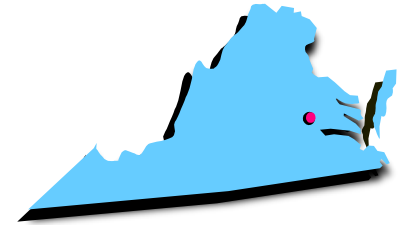

- Virginia examples:
 - Daily Planet, Richmond:
 - Offers reentry shelter access, including Safe Haven Home, MH and SA treatment and general medical care
 - Local Reentry Councils:
 - Provides interagency collaborative approach to reentry from jail or prison, including MH and SA treatment in 5 Virginia localities